

# ddrum<sup>®</sup>

## BETA XP2



ELECTRONIC DRUM SET  
USER MANUAL







# Operation Warning

## Warning & Caution Signs

 <b>WARNING</b>	This sign indicates the risk of serious physical injury or even death. Please operate the machine according to instructions.
 <b>CAUTION</b>	This sign indicates the risk of serious physical injury and even death. Please operate the machine according to instructions.  *Object damage refers to any harm or adverse effects to household, furniture, pets, and etc.

## About Signs

	This sign indicates a warning or caution. Please read the accompanied instruction to prevent any dangers.
	This sign indicates any forbidden activity.
	This sign indicates an instructional procedure for users to follow with.

**ALWAYS FOLLOW THE INSTRUCTIONS  
AS DESCRIBED BELOW**

## **WARNING**

Please read the following instructions before operation.



Do not open or in any way modify the machine or adapter.



Do not attempt to repair or replace any internal parts by yourself, unless instructed to do so by the manual. In case of technical assistance, please contact with your retailer, or their customer service, or any recognized retailers printed on the information page.



Do not store or operate the machine under the following conditions:

- Near areas with extreme temperature. (For example, in the car under the sun, near a heat venting pipe, and etc.)
- In very humid environments. (For example, in the bathroom or near other damp environments.)
- Exposing to rain or any other liquids
- In the sand.
- In shaking & unstable environments.



For proper operation, make sure that the support stands are placed on flat and stable ground in order to support the machine safely.



## **WARNING**

Please only use the adapter that is included with the unit. Make sure that the voltage of the socket matches the voltage indicated on the unit.



Please do not over-twist or over-bend the power cable, or place any objects on it. Doing so may result in short-circuit that can lead to fire and electric shock.



Please do not operate with high volume over a long period of time regardless of using an amplifier or a headphone. Doing so may prevent damage to your hearing. Should any hearing discomfort develop. Stop using and consult a hearing doctor.



Should any of the following situations result, please stop operation and remove the adapter from the socket, remove the adapter from the socket, and consult with your retailer, the nearest customer service, or any of the recognized retailers listed on the information page:

- The adapter or the power cable is damaged.
- An object, or liquid has slipped into the interior of the machine.
- The module has been exposed in rain, or has got wet.
- The module is not operating or is operating with noticeable problems.







## WARNING

If there are children in the household, the adults should follow the safety precautions explained in the manual.



Do not share the power supply with too many adapters at the same time. When using an extension power supply, please make sure that the total power usage does not exceed the limit stated on the extension power supply. Doing so may result in melting of the cables and fire.



When using the module in other countries, please consult your retailer, the nearest customer service, or any of the recognized retailers listed on the information page to find out correct voltage for that country.



## CAUTION

Always place the module and the adaptor in areas with good airflow.



When inserting or removing the power cable into/from the socket or the machine, always grab the plug instead of the cable.



If you do not plan to operate the module for a long period of time, please remove the adapter from the socket.



To prevent the cables from tangling, place the cables out of reach of children.



Do not place heavy objects on the module.



When moving the module, or during insertion/removal of the plug, always use dry hands.



Please turn off the power and remove the adapter from the socket before cleaning the module.



When there is a risk of lightning strike, please remove the adapter from the socket.



# Precautions

Please read the following precautions aside from the safety instructions

## Power Supply

- Do not share the power supply with other electronics that can produce cable statics, for example, electric motors.
- It is normal for direct current (DC) to produce heat with extended usage, and there is no need to be worried.
- Before connecting the module to other electronics, always turn off the power to prevent damage.

## Placement/Location

- Operating the module near a post-amplifier or machines that use High-power converters, buzzing may result. To prevent this problem, please change the module's facing direction, or place the machine away from the interrupting sources.
- This machine may interfere with the radios and televisions. Please do not operate the module near them.
- Do not place the module under sun, or near any heat source, as high temperature may cause the module or components to deform or discolor.
- To prevent permanent damage, please do not expose the module or components to moist or in humid environments.

## Maintenance

- For normal cleaning, please use soft cloth with little or no moist for wiping. For tougher spots, use neutral-pH and wear-free cleaner then use dry soft cloth to wipe clean.
- Never use volatile oil, diluting solutions, alcohol, or any other kinds of solvents to prevent the machine from deforming or discoloring.

## Additional Precautions

- During operation, please handle with care to prevent any damage. Do not hit or press against the display screen.
- Always grab the heads of cables during insertion/removal to prevent damage to the cables or the machine.
- To prevent disturbing your neighbors, please operate the machine at an acceptable volume, or use a headphone, especially at night.
- Although this electronic drum set is designed to minimize unwanted noise during operation, the percussive sound may still pass through the floor or walls, resulting in unexpected noise. Please be careful not to let such sound disturb your neighbors, especially at night.
- When transporting, please use the original or similar packaging and box.
- Please use official cables for connection. When using cables from other companies, please note the following: Some cables may consist of resistors, which may be incompatible and result in extremely low volume. For information about the specifications of cables, please consult with the manufacturer.
- Please do not hit the pads with excessive force to prevent the risk of hurting your fingers.

## Accessories

**A1**



Sound Module

**x1**

**A2**



Snare Pad  
(1/4" jack)

**x1**

**A3**



Tom Pad  
(3.5mm jack)

**x3**

**A4**



Cymbal

**x3**

**A5**

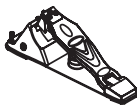

Hi-hat  
Controller

**x1**

**A6**



Kick Pedal

**x1**

**A7**

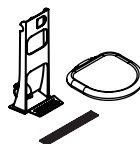

Bass Drum &  
Double Slip Resistant Tape

**x1**

## Accessories

## Connectors

**A8**



drum throne

**x1**

**B1**



User  
Manual

**x2**

**B2**



Cable Tie

**x2**

**B3**



Drum Stick  
(1 set)

**x1**

**B4**



Drum Key

**x1**

**B5**



Headphones

**x1**

**B6**



Velcro

**x6**

**C1**

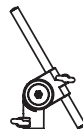

Adjustable Bar

**x3**

## Connectors

## Parts

**C2**



Ø1.27(cm) Pad  
Connector

**x4**

**C3**



Ø3.81(cm)  
Double Screws  
U-shape Plate &

**x1**

**P1**



Floor Pad

**x4**

**P2**



Ø3.81(cm)  
Stopper

**x4**

**P3**



Ø2.22(cm)  
Stopper

**x2**

**P4**



Wing Bolt

**x22+2**

**P5**



Nut

**x21+2**

**P6**



Ø3.81 - Ø2.22  
Adjustable  
Connector

**x1**

Spare Parts

**L1**

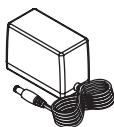

Adapter

**x1**

**L2**



L-L Mono  
Sound Cable  
(Black)

**x4**

**L3**

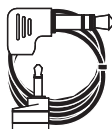

L-L Stereo  
Sound Cable  
(Red)

**x3**

**L4**

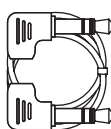

L-L Stereo  
Sound Cable  
(Red)

**x1**

**L5**













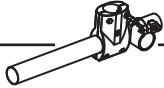

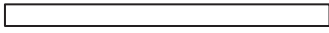

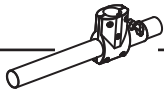



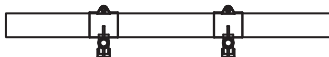

L-L Mono  
Sound Cable  
(Black)

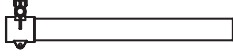
**x1**

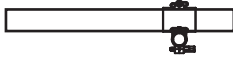

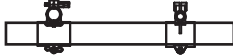



## WARNING

**Please note:**  
whenever you insert  
or pull the plug out  
of a socket or adapter,  
hold the plug. Do not  
pull on the cable.

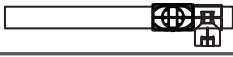
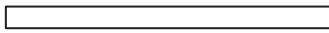
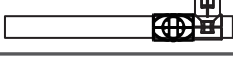
## Support Stand

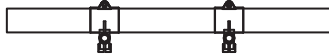
	<b>▼ Ø3.81cm</b>			
<b>S1</b>			<b>40 cm × 1</b>	
<b>S2</b>			<b>57 cm × 1</b>	
<b>S3</b>			<b>40 cm × 1</b>	
<b>S4</b>			<b>75 cm × 1</b>	
<b>S5</b>			<b>57 cm × 1</b>	
<b>S6</b>			<b>75 cm × 1</b>	
<b>S7</b>			<b>40 cm × 1</b>	
<b>S8</b>			<b>40 cm × 1</b>	
<b>S9</b>			<b>40 cm × 1</b>	
<b>S10</b>	<b>▼ Ø2.22cm</b>		<b>40 cm × 3</b>	
<b>S11</b>	<b>▼ Ø1.27cm</b>		<b>20 cm × 4</b>	

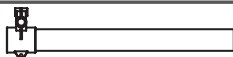
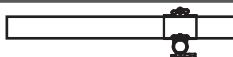
### Step 1

<b>S1</b>		<b>40 cm × 1</b>
<b>S2</b>		<b>57 cm × 1</b>
<b>S3</b>		<b>40 cm × 1</b>
<b>S4</b>		<b>75 cm × 1</b>
<b>S5</b>		<b>57 cm × 1</b>
<b>S6</b>		<b>75 cm × 1</b>
<b>S7</b>		<b>40 cm × 1</b>
<b>S8</b>		<b>40 cm × 1</b>
<b>S9</b>		<b>40 cm × 1</b>

Step 1

P1



x4

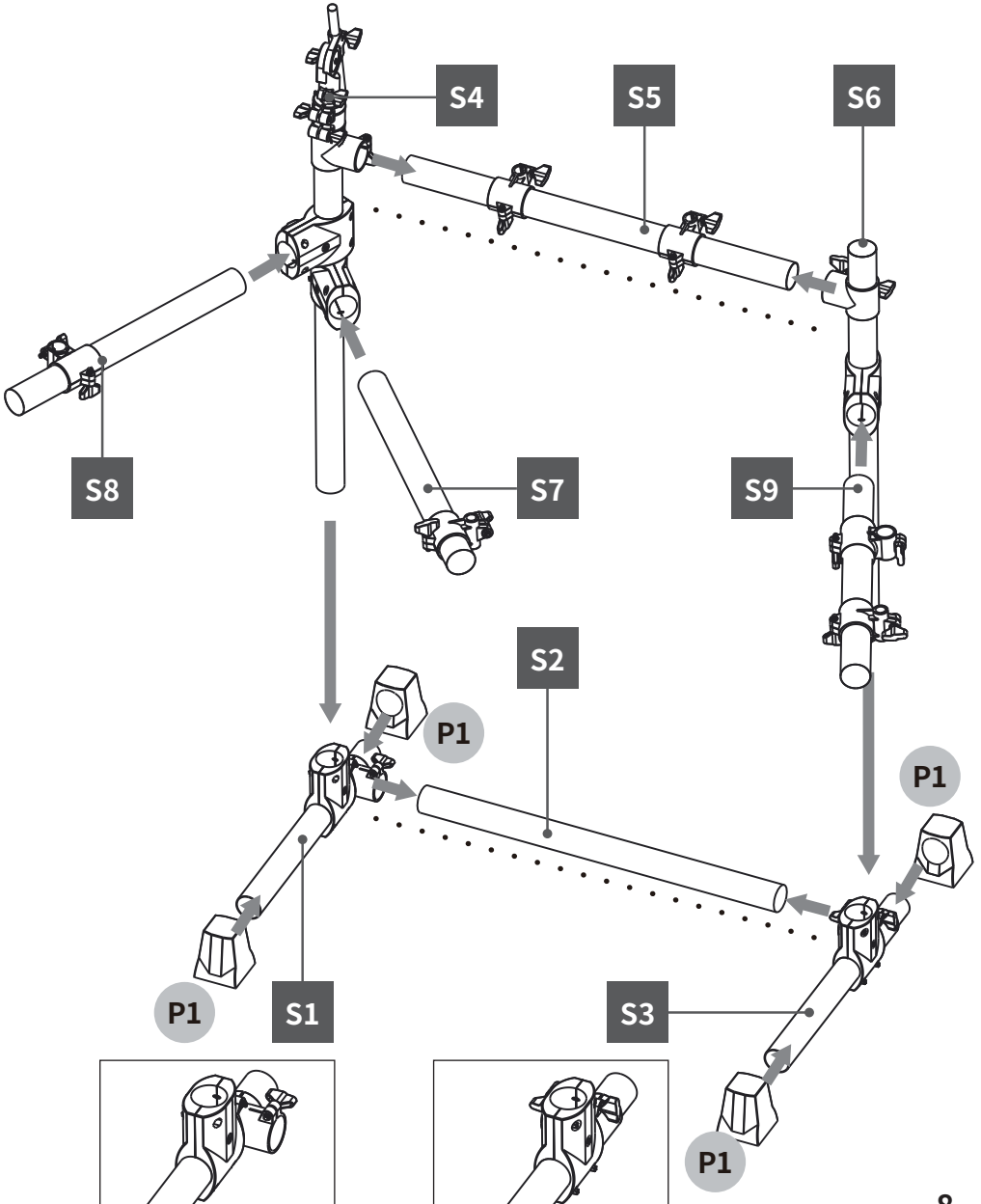

**Step 2**

**S10**  $\overline{\text{Ø}2.22\text{cm}}$  40 cm × 3

**S11**  $\nabla \text{Ø}1.27\text{cm}$  20 cm × 4

**C1**



**P6**

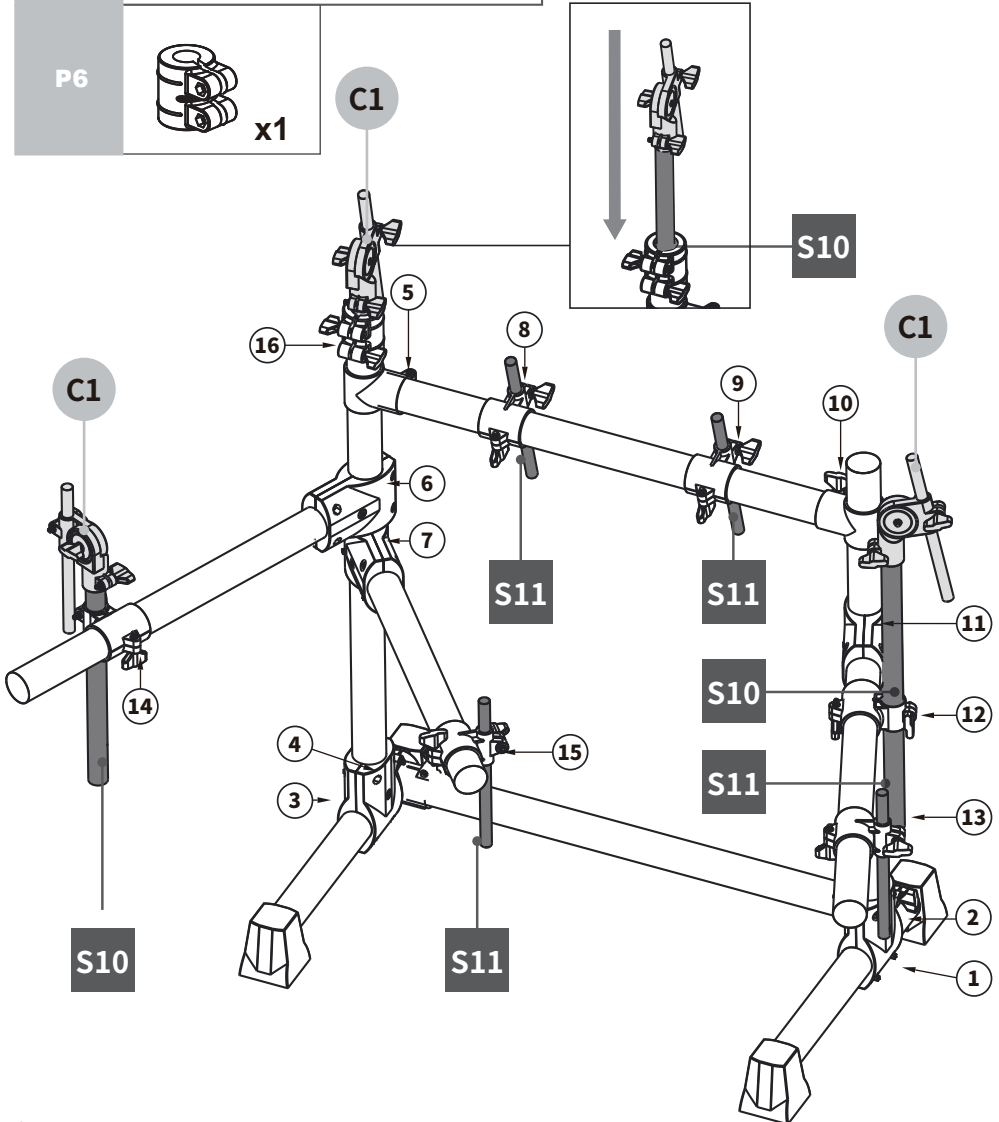

Step 3

P4



x12

P5



x12

T2

T1

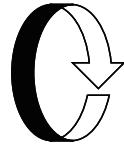

8 9 13 15

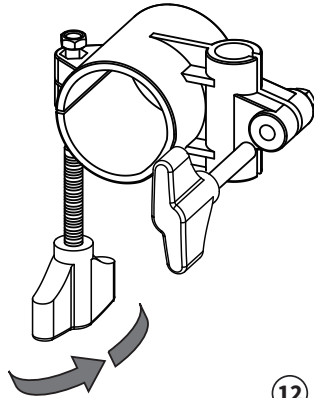

12 14

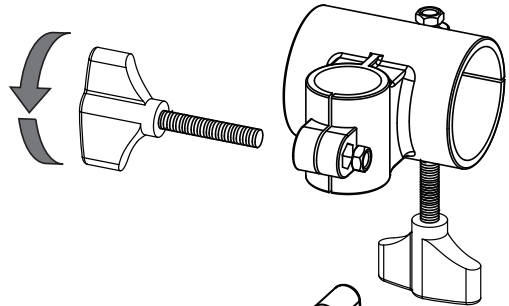



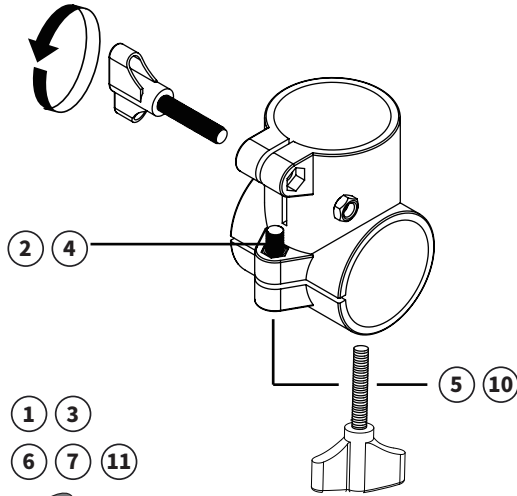
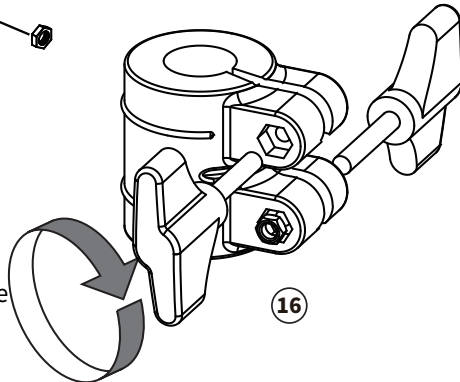

16

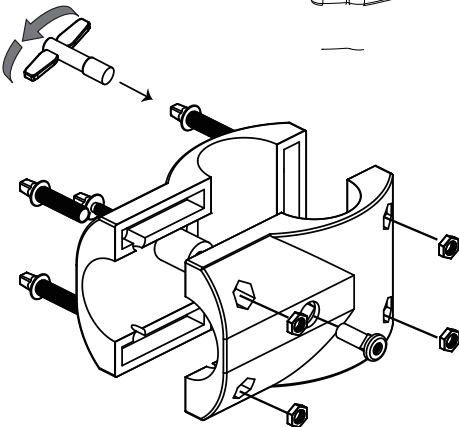

1 3  
6 7 11



**Attention:** When assembling this connector, tighten each of the bolts in a square pattern. Do not tighten one bolt at a time. This will cause the connector to be uneven.

Step 4	
A2	 x1
A3	 x3
P4	 x8
P5	 x8
C2	 x4

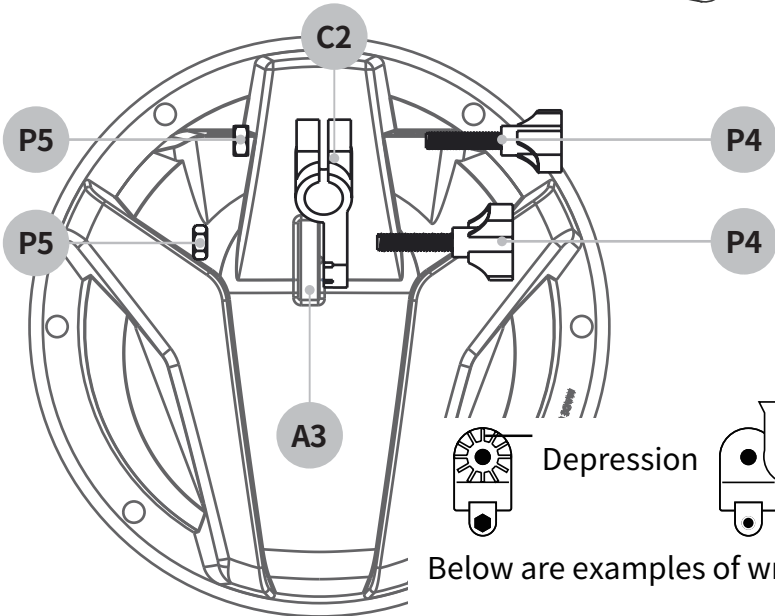
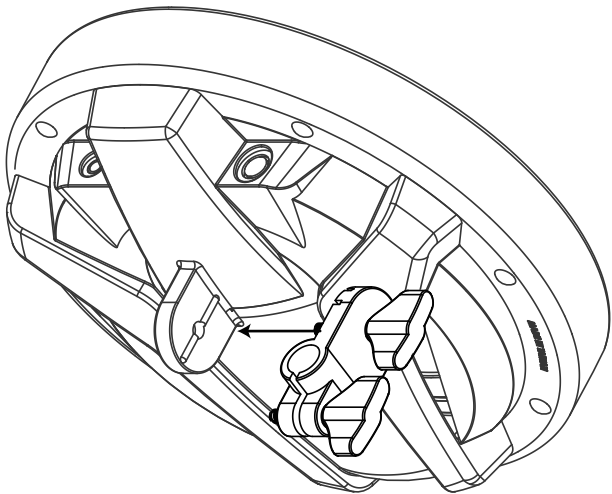



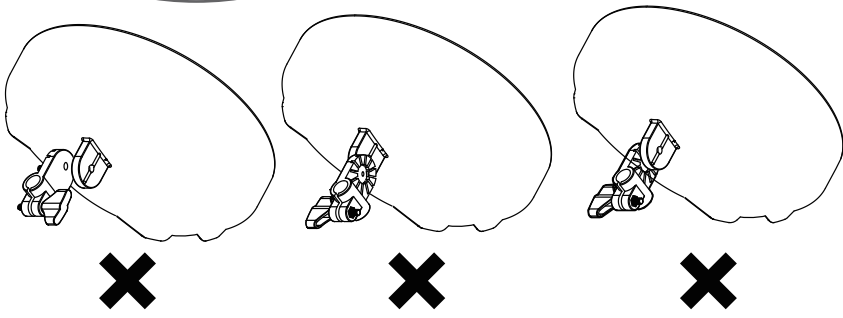

Below are examples of wrong assembly.

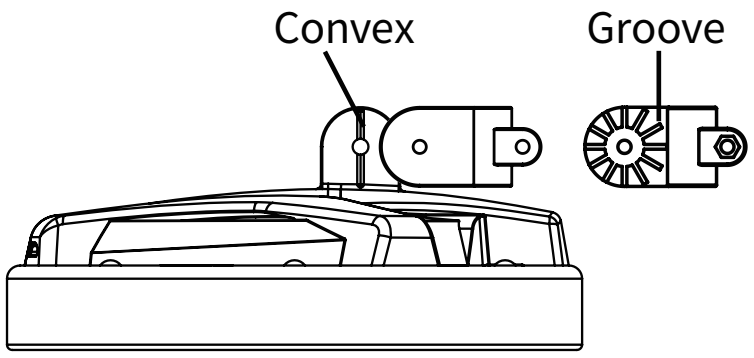
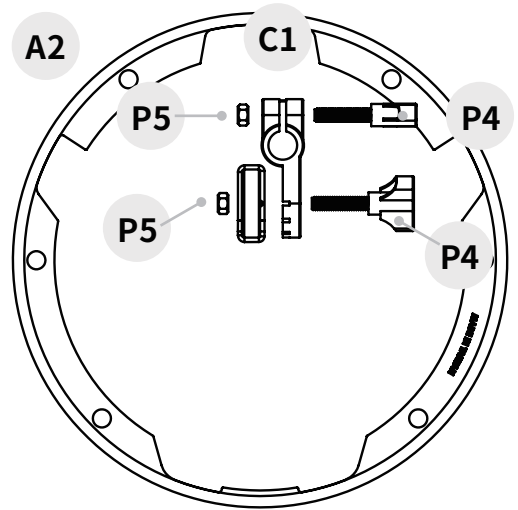
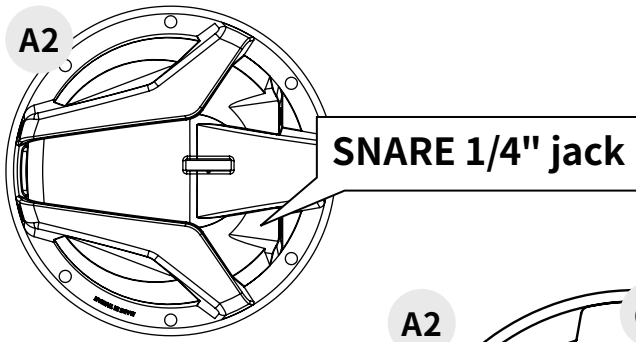









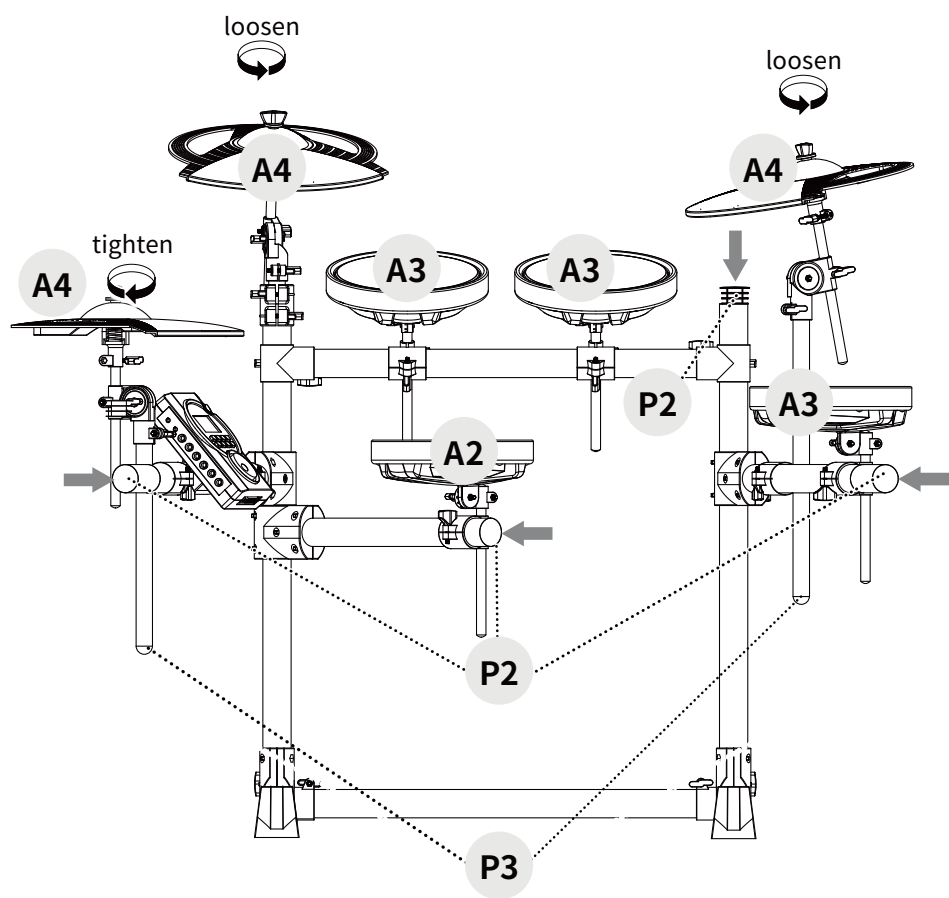
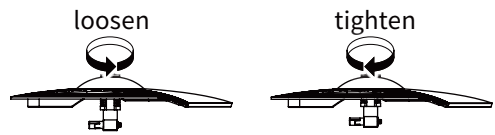

Match the convex side of pad with the groove side of connector .

Step 5		
A2		x1
A3		x3
A4		x3
P2		X4
P3		X2

**NOTE** Loosen or tighten the nut to adjust cymbal.

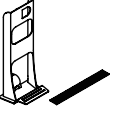

## Bass Drum

<b>A7</b>		x1	<b>A6</b>		x1	<b>T1</b>		x2
<b>A7</b>		x1				<b>T2</b>		x1

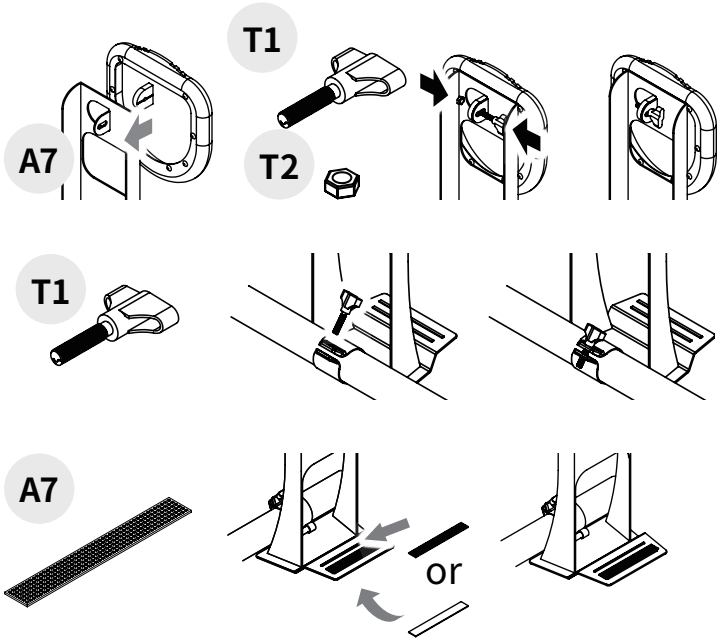

The slip resistant tape compensate for varying kick pedal heights.

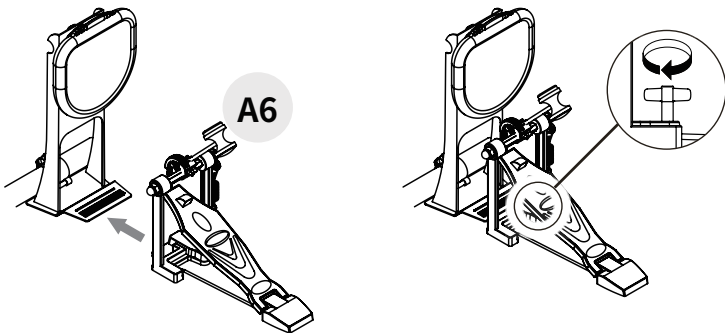

## Mounting on the stand

A1



x1

C3



x1

Position the sound module onto the bar and bring the U-Shape plate upwards around the bar.

Secure the U-Shape plate to the back of the sound module with the screws provided.

Remove the protective film from the display screen.

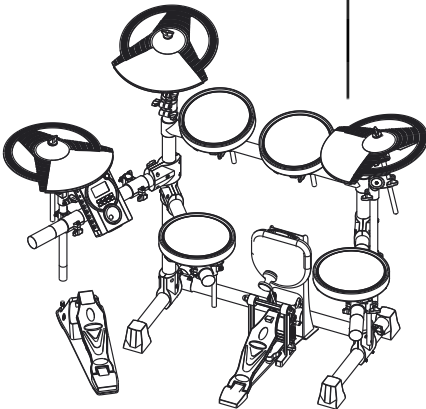
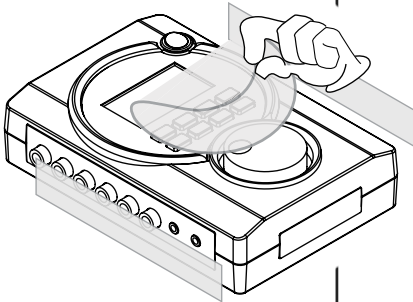

A1

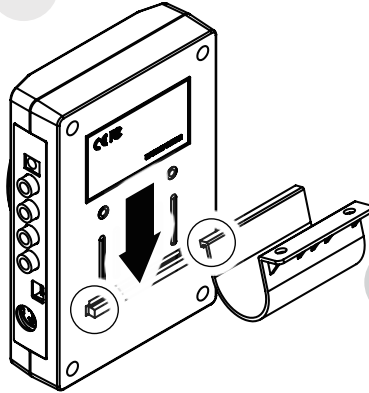

C3

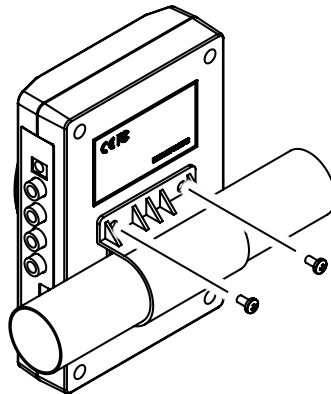
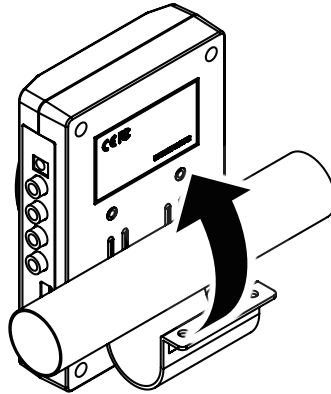

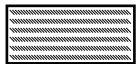
Controller		
A5		x1
B6		x6

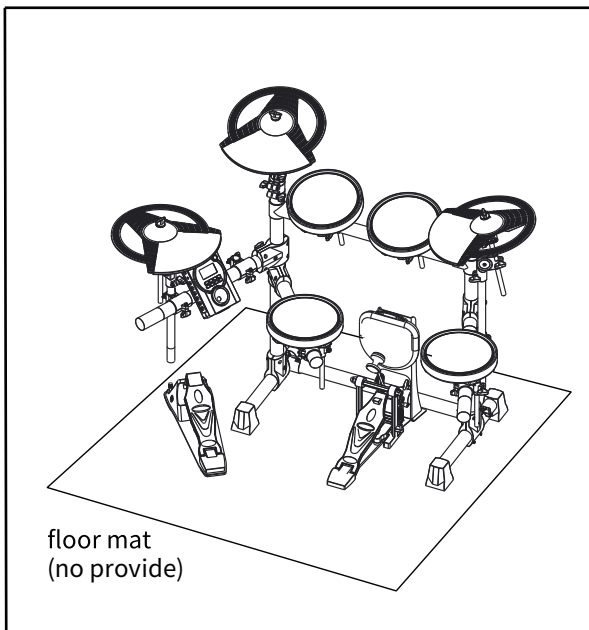
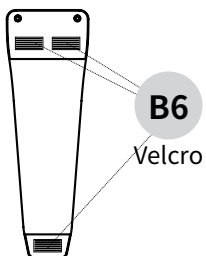

Choke Effect		
A4		x3

- ① HI-HAT
- ④ CYMBAL 1
- ⑦ CYMBAL 2

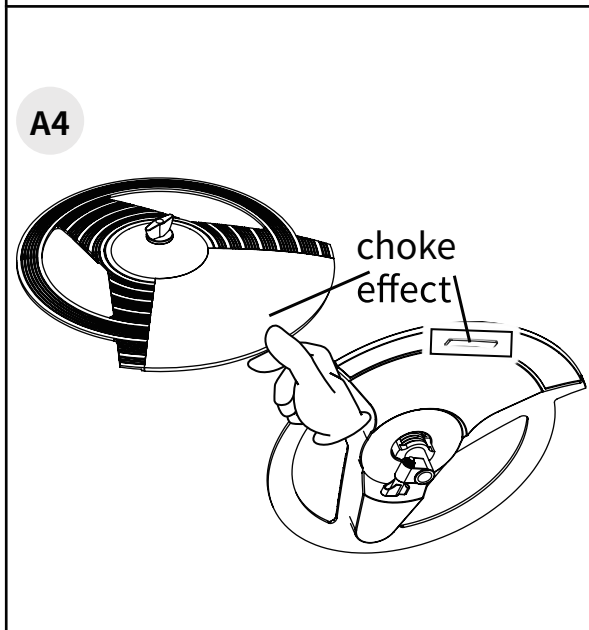

## Sound Cable

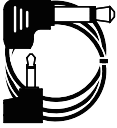
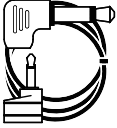
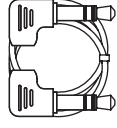
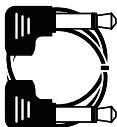
L2	(Black) 	x4
L3	(Red) 	x3
L4	(Red) 	x1
L5	(Black) 	x1

Connect the sound cables to the drum pads, pedals and sound module.

 Stereo cable  
(two black lines)

### WARNING

**Please note:** whenever you insert or pull the plug out of a socket or adapter, hold the plug. Do not pull on the cable.

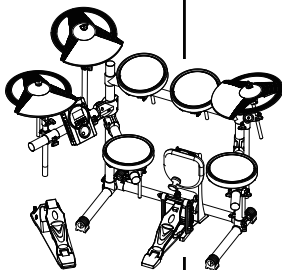

② SNARE  
(Red)

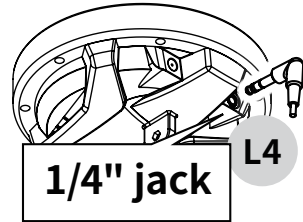

③ TOM1  
⑧ TOM2  
⑨ TOM3  
(Black)

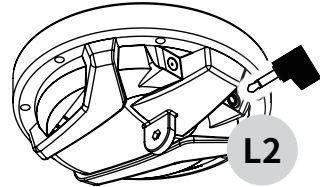

L3

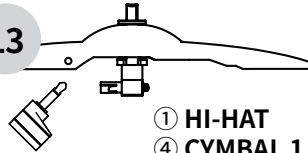

① HI-HAT  
④ CYMBAL 1  
⑦ CYMBAL 2  
(Red)

⑤ HI-HAT CTRL  
(Black)

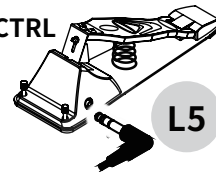

L2

⑩ BASS DRUM  
(Black)

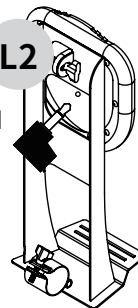

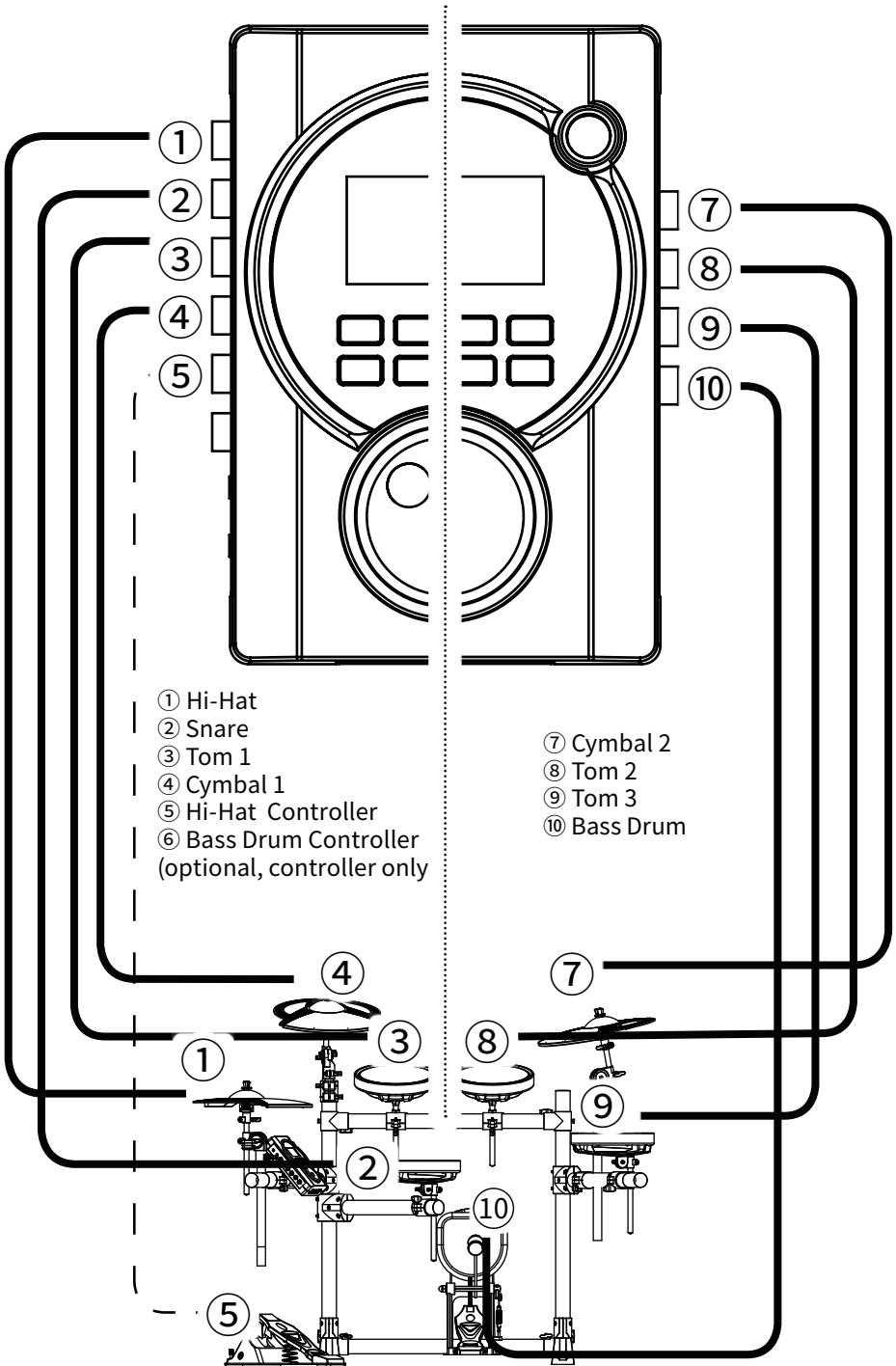

- ① Hi-Hat
- ② Snare
- ③ Tom 1
- ④ Cymbal 1
- ⑤ Hi-Hat Controller
- ⑥ Bass Drum Controller  
(optional, controller only)

- ⑦ Cymbal 2
- ⑧ Tom 2
- ⑨ Tom 3
- ⑩ Bass Drum

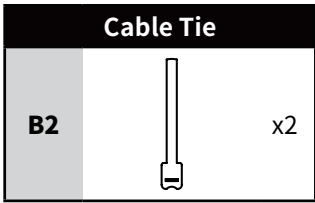

Lead the cable along the mounting rack and stabilize it with the included cable tie.

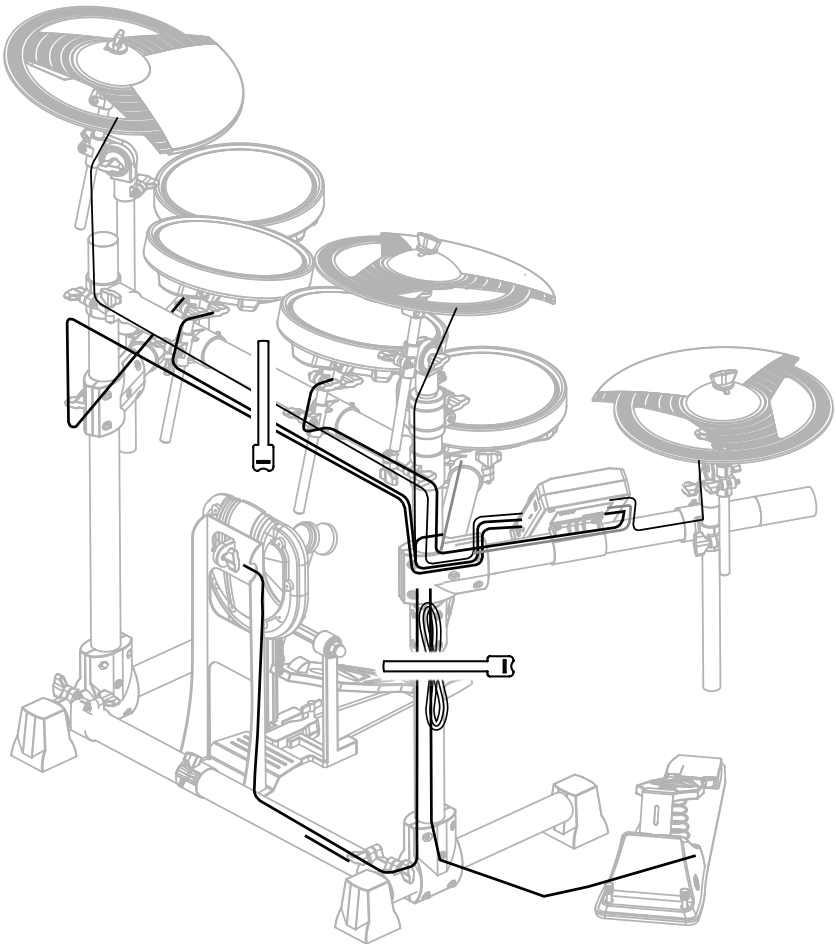



**2-zone** ② Snare

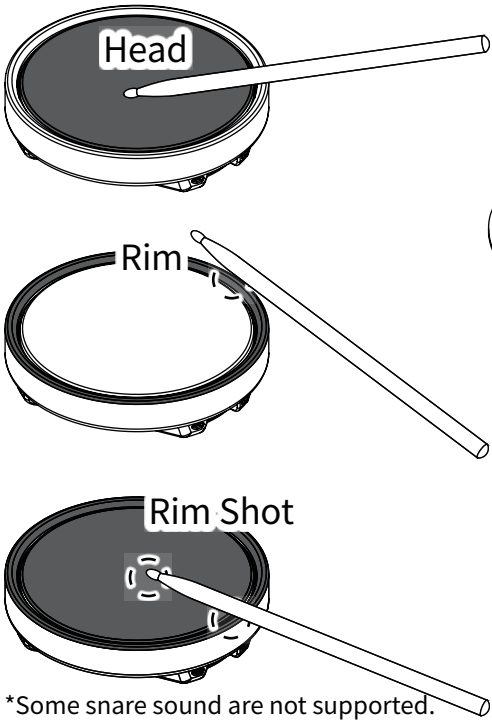

**1-zone+choke**

- ① Hi-Hat
- ④ Cymbal 1
- ⑦ Cymbal 2

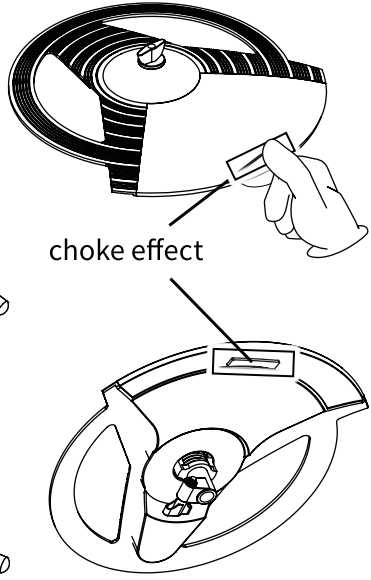

**Continuous Type** ⑤ Hi-Hat Controller

More realistic Hi-Hat effects transition between open and closed, such as full open, half open, full closed, foot splash.

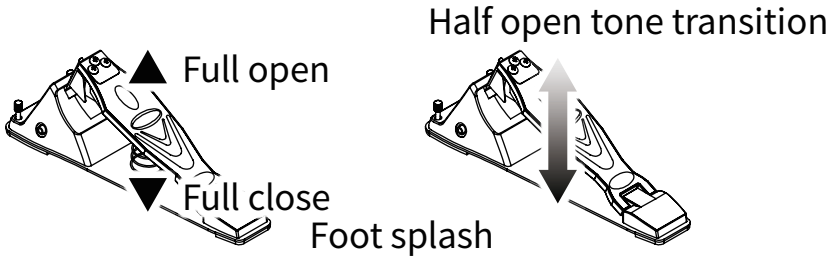

Step 10

A8

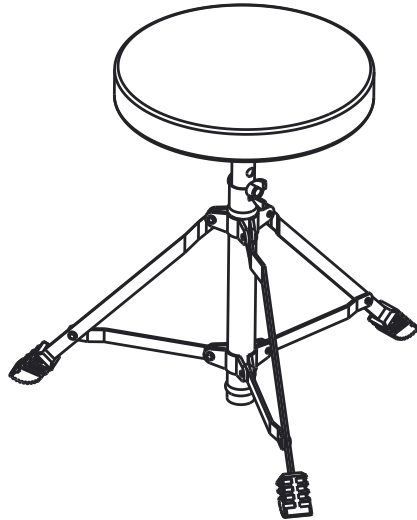
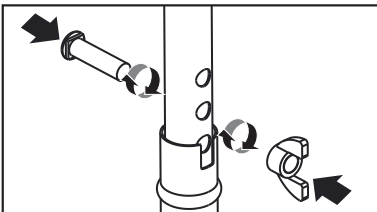
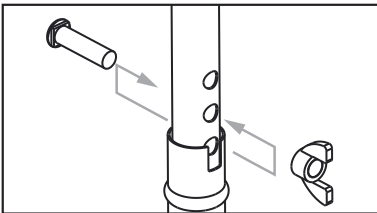
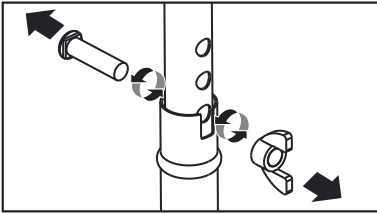
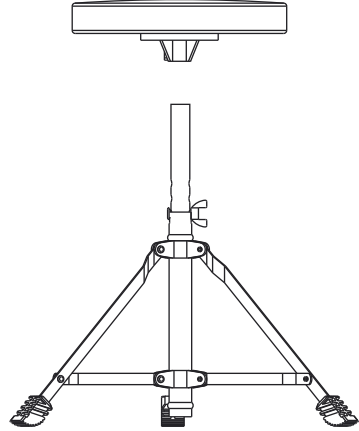
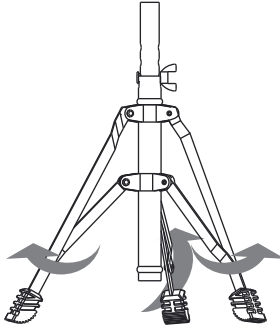
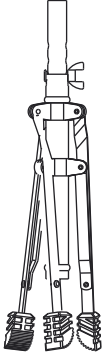

1. Loosen the bolt and nut.
2. Adjust the pipe to the desired height
3. Tighten the bolt and nut to stabilize the throne.



**ddrum<sup>®</sup>**

For more information please visit our website

**[www.ddrum.com](http://www.ddrum.com)**